

AIR SIDE CRIMP PLUG ASSEMBLY FOR FA19649

FIG 1

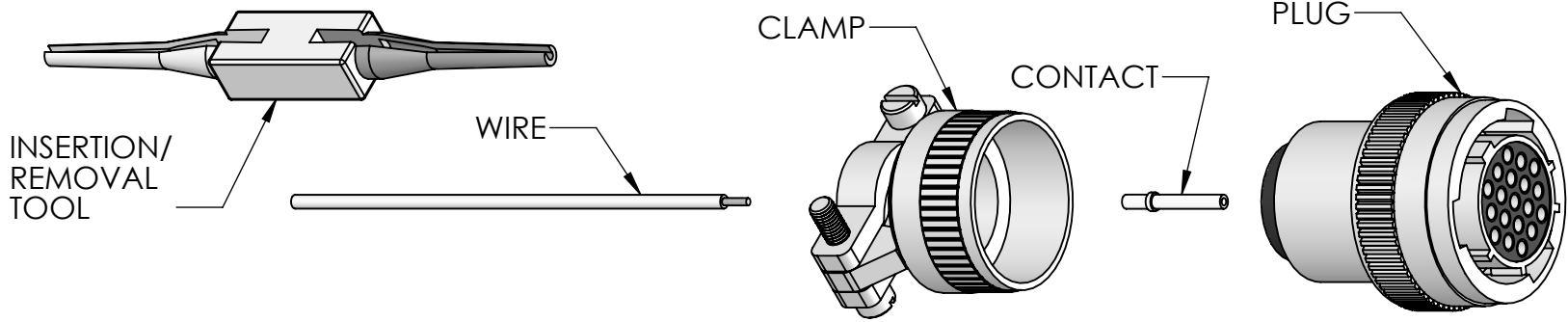
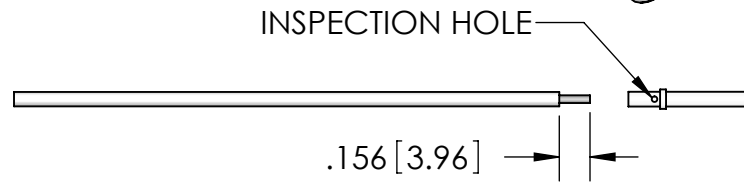
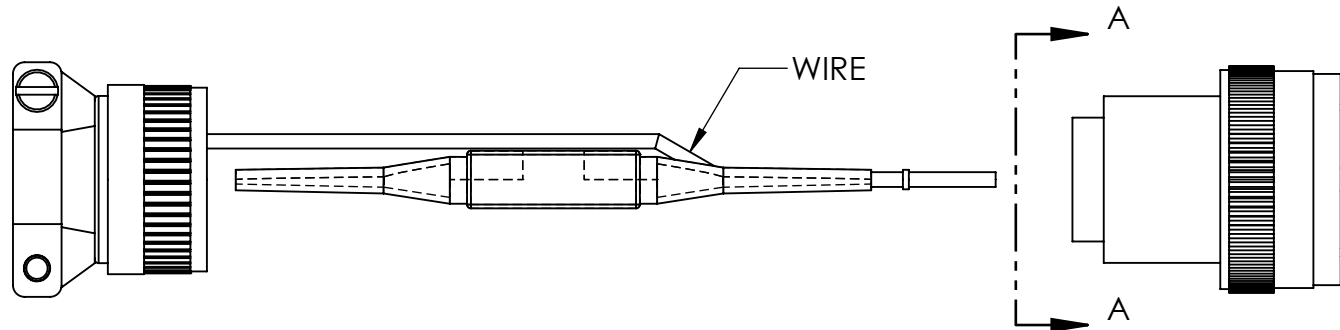

FIG 2



STRIP END OF WIRE TO DIMENSION SHOWN. INSERT WIRE FULLY INTO CONTACT, WIRE SHOULD BE VISIBLE IN INSPECTION HOLE. CRIMP WIRE TO CONTACT USING CRIMP TOOL SST P/N FP44440 AND LOCATOR SST P/N FP44441.

FIG 3



SLIDE CONTACT AND WIRE THROUGH CLAMP. THEN SLIDE CONTACT AND WIRE INTO RED END OF INSERTION TOOL. BEGINNING FROM THE CENTER CAVITY AND WORKING OUTWARDS IN A CIRCULAR PATTERN, INSERT WIRED CONTACTS INTO PLUG. (SEE FIG 4 VIEW A-A ON SHEET 2 FOR CONTACT LOCATIONS.) PUSH TOOL STRAIGHT INTO CAVITY UNTIL CONTACT SNAPS INTO POSITION. A LIGHT PULL ON THE WIRE WILL ASSURE THAT THE CONTACT IS SECURELY IN POSITION. REMOVE INSERTION TOOL AND REPEAT.

PROPRIETARY AND CONFIDENTIAL

THE INFORMATION CONTAINED IN THIS DRAWING IS THE SOLE PROPERTY OF SOLID SEALING TECHNOLOGY. ANY REPRODUCTION IN PART OR AS A WHOLE WITHOUT THE WRITTEN PERMISSION OF SOLID SEALING TECHNOLOGY IS PROHIBITED.

THIRD ANGLE PROJECTION

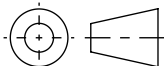

TITLE:

**INSTRUCTION SHEET
9 PAIR T/C PLUG ASSEMBLY**



**SOLID SEALING
TECHNOLOGY**

REV.	APP'D	DATE	SCALE 1:1	DIMENSIONS IN INCHES [mm]	DRAWN	JS	07/19/2011	NUMBER:
E	JF	02/04/2025	NS19649-11		ENG APPR.	JS	07/19/2011	

NS19649

REV: **E**

SHEET 1 OF 2

**FIG 4
VIEW A-A**

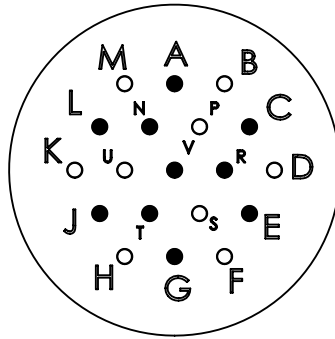

CONTACT LOCATIONS

LOCATION	CONTACT MATERIAL	CONTACT P/N	COLOR BANDS
SHADED	CHROMEL (+)	CP13353-02	BROWN-YELLOW-BROWN
UNSHADED	ALUMEL (-)	CP13353-03	BROWN-YELLOW-BLACK

FIG 5

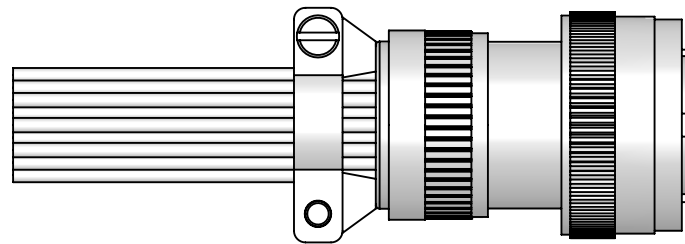

TIGHTEN CLAMP ONTO PLUG

PROPRIETARY AND CONFIDENTIAL THE INFORMATION CONTAINED IN THIS DRAWING IS THE SOLE PROPERTY OF SOLID SEALING TECHNOLOGY. ANY REPRODUCTION IN PART OR AS A WHOLE WITHOUT THE WRITTEN PERMISSION OF SOLID SEALING TECHNOLOGY IS PROHIBITED.				THIRD ANGLE PROJECTION 		TITLE 9 PAIR T/C PLUG ASSEMBLY			
REV.	APP'D	DATE	SCALE 1:1	DIMENSIONS IN INCHES [mm]	DRAWN	JS	07/19/2011	NUMBER	REV
E	JF	02/04/2025	MPC10374-11		ENG APPR.	JS	07/19/2011		
								SHEET 2 OF 2	