

### ASSEMBLY INSTRUCTIONS:

- 1- INSERT WIRES THROUGH CONTACT RETAINER AND CRIMP TO CONTACTS. USE CRIMP TOOL SST P/N FP44440 AND LOCATOR SST P/N FP44441.
- 2- AFTER CRIMPING SEAT CONTACTS INTO PLUG.
- 3- INSERT CONTACT RETAINER INTO PLUG.
- 4- INSTALL RETAINING RING INTO GROOVE IN BACK OF PLUG.
- 5- CONTACTS ACCEPT A  $\phi$ .04 [1.0] PIN AND 20-24 AWG WIRE SIZE FOR CRIMP.
- 6- MAXIMUM WIRE INSULATION OD: .079 [2.0]

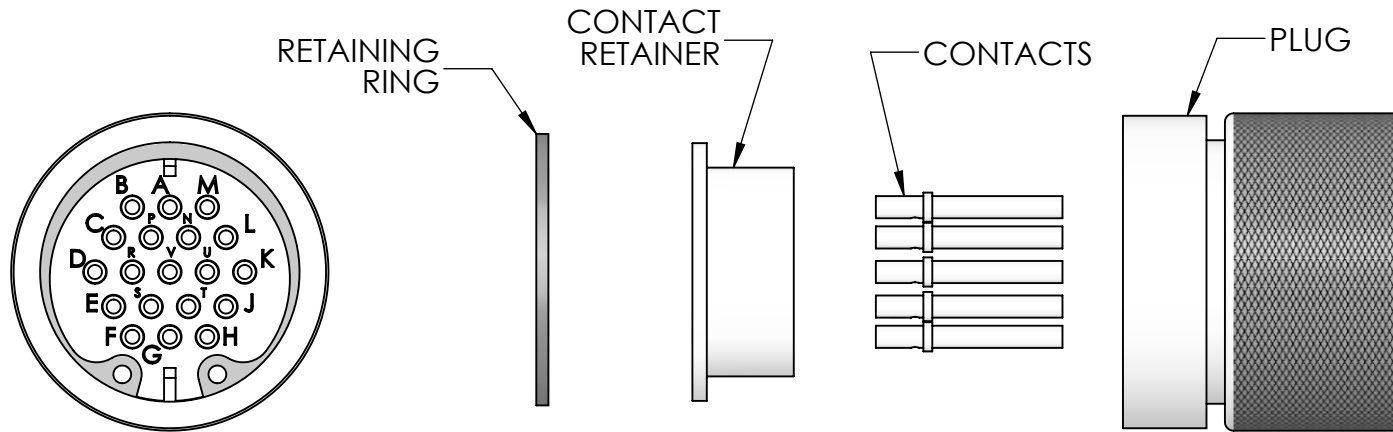

APPLIES TO:	
No. OF PINS	PLUG P/N
3	FA18064
6	FA18067
10	FA13461
19	FA13462
32	FA13463
41	FA13464

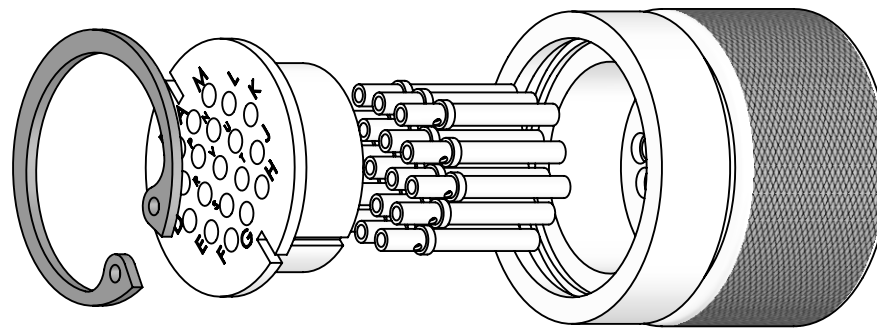

PROPRIETARY AND CONFIDENTIAL  
 THE INFORMATION CONTAINED IN THIS DRAWING IS THE  
 SOLE PROPERTY OF SOLID SEALING TECHNOLOGY. ANY  
 REPRODUCTION IN PART OR AS A WHOLE WITHOUT THE WRITTEN  
 PERMISSION OF SOLID SEALING TECHNOLOGY IS PROHIBITED.

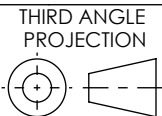

TITLE: **INSTRUCTION SHEET**  
**26482 PLUG ASSEMBLY**



REV.	APP'D	DATE	SCALE 1.5:1	DIMENSIONS IN INCHES [mm]	DRAWN	MH	01/24/2008
F	JF	02/04/2025	MSME0006-01EX		ENG APPR.	MH	01/24/2008

NUMBER: **NS13462**

REV: **F**

SHEET 1 OF 1