

NOTES:

1. THIS IS AN ACCESSORY NUT FOR USE ON SST FIBER OPTIC JAM NUT / BASEPLATE FEEDTHROUGH ADAPTERS. IT IS DESIGNED TO BE USED WHEN MOUNTING THE FEEDTHROUGH TO AN UNTHREADED PANEL.
2. MATERIAL: 300 SERIES STAINLESS STEEL

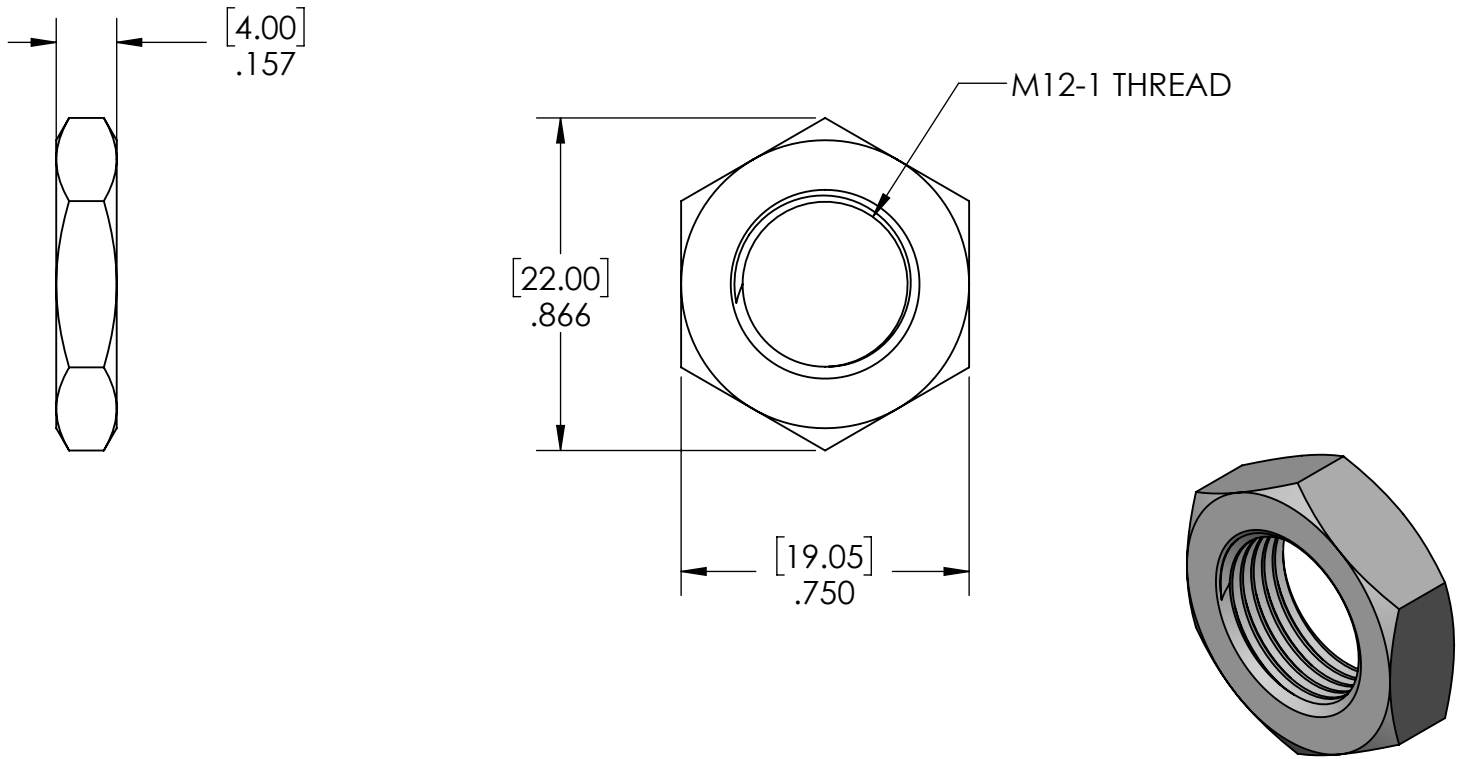

WWW.SOLIDSEALING.COM



SOLID SEALING TECHNOLOGY, INC.

SALES DWG NO. FP38340SL REV. A1

PROPRIETARY AND CONFIDENTIAL

THE INFORMATION CONTAINED IN THIS DRAWING IS THE SOLE PROPERTY OF SOLID SEALING TECHNOLOGY. ANY REPRODUCTION IN PART OR AS A WHOLE WITHOUT THE WRITTEN PERMISSION OF SOLID SEALING TECHNOLOGY IS PROHIBITED.

THIRD ANGLE PROJECTION

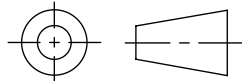

TITLE:

HEX NUT, OPTICAL FIBER FDTHR

PART NO. FP38340 REV. A

REV.	APP'D	DATE	SCALE 2:1	DIMENSIONS IN INCHES [mm]	DRAWN	HJ	10/30/2018
A1	JF	12/31/2018	AHDFS082-11		ENG APPR.	JF	12/31/2018

**DIMENSIONS ARE FOR REFERENCE ONLY. UNLESS NOTED, NO TOLERANCES ARE IMPLIED. CONSULT SST TO DISCUSS YOUR SPECIFIC REQUIREMENTS.**