

PERFORMANCE SPECIFICATIONS	
SURFACE QUALITY	40-20 OR BETTER
PARALLELISM	30 ARC MINUTES MAX
TRANSMITTED WAVEFRONT DISTORTION (TWD) (FLATNESS)	$< \lambda/4$ @ 633nm
TEMPERATURE	-100°C TO 200°C
PRESSURE	250 PSIG @ 20°C

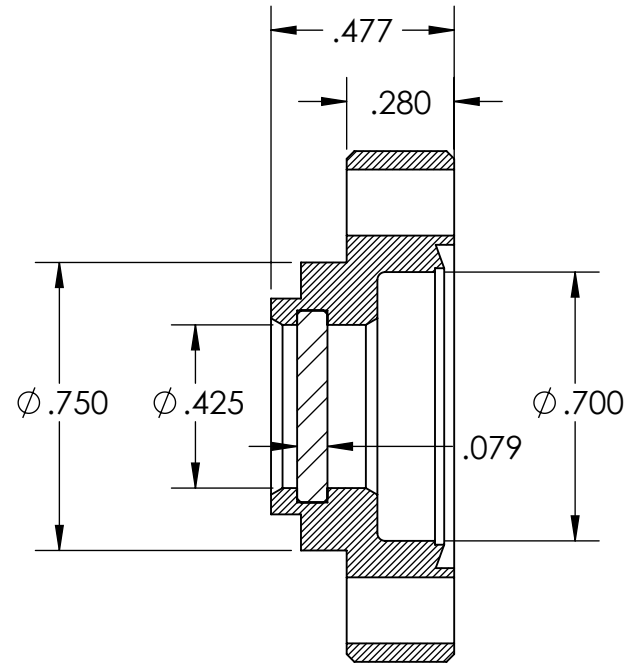
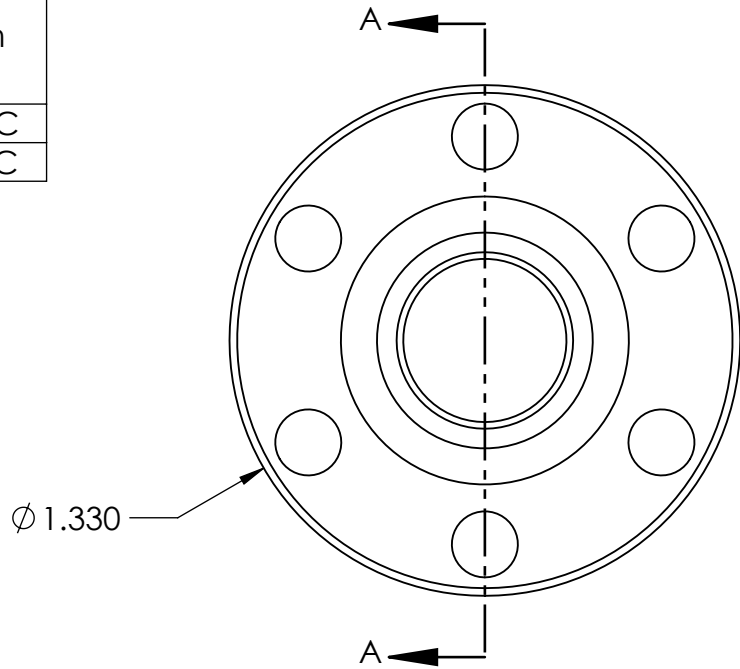

SECTION A-A

PART No	WINDOW MATERIAL	FLANGE MATERIAL
FA48786	ZINC SELENIDE IR	304 STN STL
FA48786-11	ZINC SELENIDE 8-12 BBAR	304 STN STL
FA48786-21	ZINC SELENIDE IR	316 STN STL
FA48786-31	ZINC SELENIDE 8-12 BBAR	316 STN STL

PROPRIETARY AND CONFIDENTIAL THE INFORMATION CONTAINED IN THIS DRAWING IS THE SOLE PROPERTY OF SOLID SEALING TECHNOLOGY. ANY REPRODUCTION IN PART OR AS A WHOLE WITHOUT THE WRITTEN PERMISSION OF SOLID SEALING TECHNOLOGY IS PROHIBITED.				THIRD ANGLE PROJECTION 		TITLE ZnSe VIEWPORT IN 1.33 FLANGE			
REV.	APP'D	DATE	SCALE 2:1	DIMENSIONS IN INCHES [mm]	DRAWN	MH	10/12/2023	PART NO. FA48786 REV. A WWW.SOLIDSEALING.COM	
A1	MH	1/3/2024	VPWD0050-00		ENG APPR.	MH	1/3/2024		

DIMENSIONS ARE FOR REFERENCE ONLY. UNLESS NOTED, NO TOLERANCES ARE IMPLIED. CONSULT SST TO DISCUSS YOUR SPECIFIC REQUIREMENTS.