

ASSEMBLY INSTRUCTIONS:

- 1- INSERT WIRES THROUGH CONTACT RETAINER AND CRIMP TO CONTACTS. USE CRIMP TOOL FP13347
- 2- AFTER CRIMPING SEAT CONTACTS INTO PLUG.
- 3- INSERT CONTACT RETAINER INTO PLUG.
- 4- INSTALL RETAINING RING INTO GROOVE IN BACK OF PLUG.
- 5- CONTACTS ACCEPT A ϕ .04 [1.0] PIN AND 20-24 AWG WIRE SIZE FOR CRIMP.
- 6- MAXIMUM WIRE INSULATION OD: .079 [2.0]

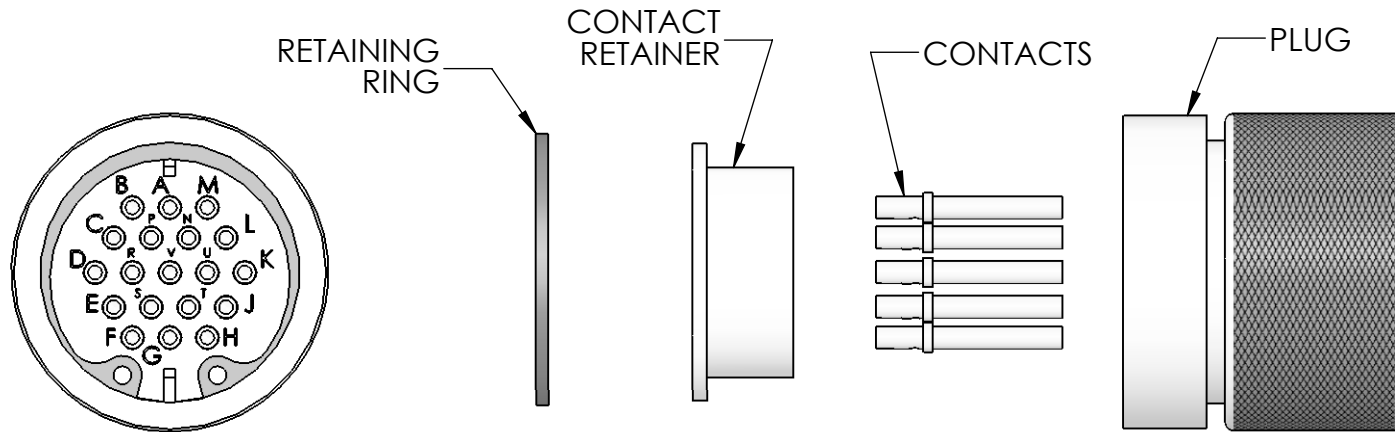

APPLIES TO:	
No. OF PINS	PLUG P/N
3	FA18064
6	FA18067
10	FA13461
19	FA13462
32	FA13463
41	FA13464

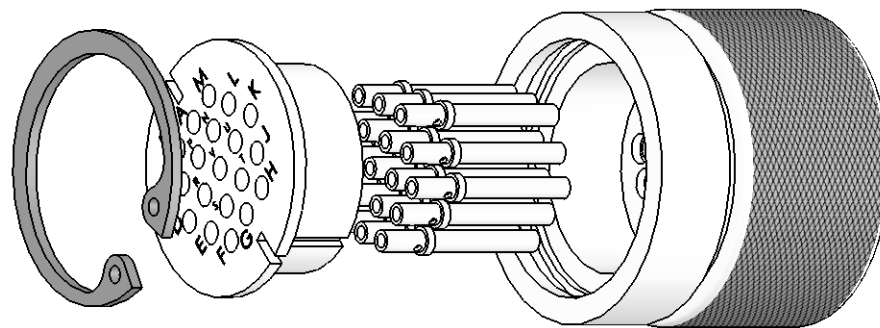

PROPRIETARY AND CONFIDENTIAL

THE INFORMATION CONTAINED IN THIS DRAWING IS THE SOLE PROPERTY OF SOLID SEALING TECHNOLOGY. ANY REPRODUCTION IN PART OR AS A WHOLE WITHOUT THE WRITTEN PERMISSION OF SOLID SEALING TECHNOLOGY IS PROHIBITED.

THIRD ANGLE PROJECTION

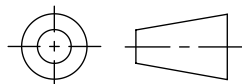

TITLE: INSTRUCTION SHEET
26482 PLUG ASSEMBLY



REV.	APP'D	DATE	SCALE 1.5:1	DIMENSIONS IN INCHES [mm]
D	JF	10/05/2015	MSME0006-01EX	

DRAWN	MH	01/24/2008
ENG APPR.	MH	01/24/2008

NUMBER: NS13462

REV: D

SOLID SEALING TECHNOLOGY, INC.
SHEET 1 OF 1