

INSTALLATION WELDING OPTIONS

- 1- E.B. OR LASER WELDING
- 2- PULSED TIG WELDING

SUB-D CONNECTORS WELDING INSTRUCTIONS

MATING HARDWARE DIMENSIONS/ CONFIGURATION

SEE SHEET 2 OF THIS INSTRUCTION SHEET.
HARDWARE SHOULD BE 304 OR 316 STAINLESS STEEL.
PREFERRED ORIENTATION IS WITH THE WELD ON THE VACUUM SIDE.

PULSED TIG WELD PROCEDURE

- 1- TYPICAL WELDER SETTINGS
 - BACKGROUND CURRENT: FIXED AT 1/5 OF PEAK CURRENT
(eg. 5amps @ 25amps)
 - CURRENT SETTING: 25 TO 30 AMPS
 - PULSE FREQUENCY: 400Hz
 - PULSE WIDTH FIXED AT 50%
- 2- TACK WELD 4 PLACES (6 PLACES ON 50 PIN) EQUALLY SPACED AROUND THE CONNECTOR
- 3- WELD TRAVEL SPEED SHOULD BE OPTIMIZED TO REDUCE HEAT INPUT (e.g. 1/4" PER SECOND)
- 4- OPPOSITE SIDE OF HEADER SHOULD BE FLOODED WITH INERT GAS FOR EXTRA COOLING AND TO MINIMIZE OXIDATION

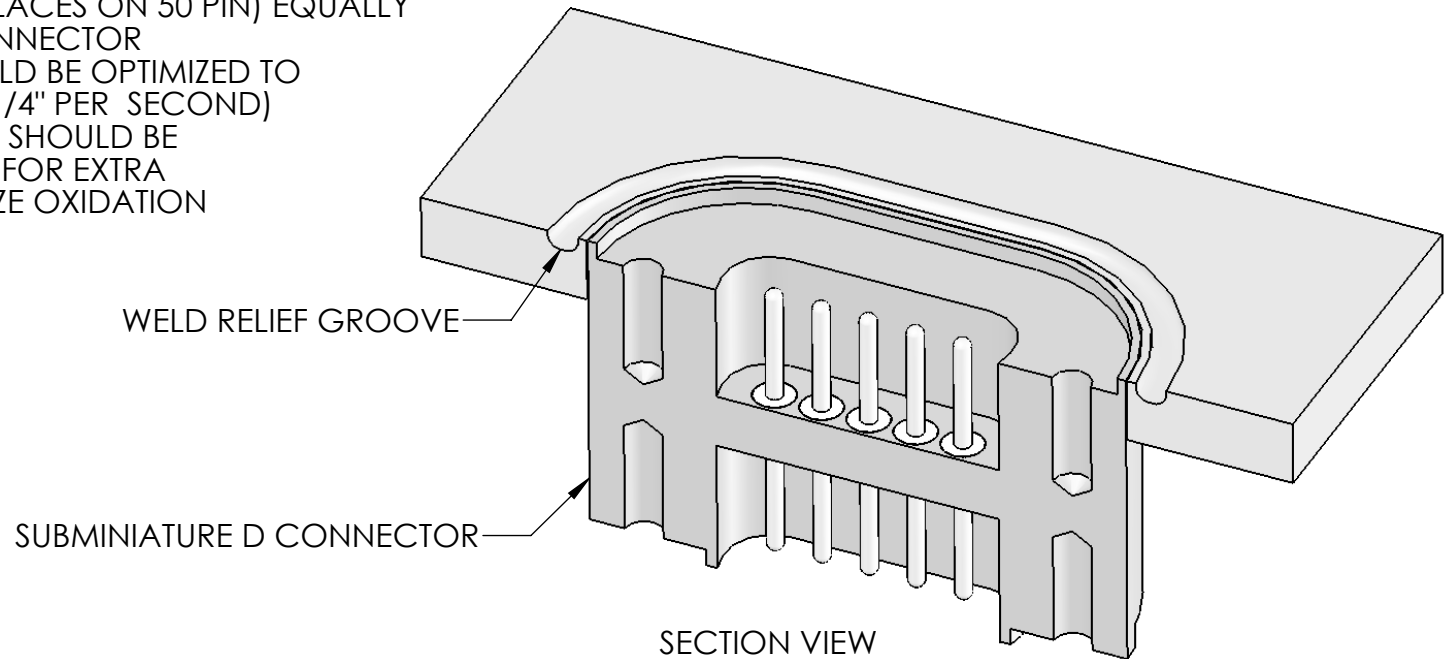

- SEE SHEET 2 FOR HOLE DIMENSIONS -

PROPRIETARY AND CONFIDENTIAL THE INFORMATION CONTAINED IN THIS DRAWING IS THE SOLE PROPERTY OF SOLID SEALING TECHNOLOGY. ANY REPRODUCTION IN PART OR AS A WHOLE WITHOUT THE WRITTEN PERMISSION OF SOLID SEALING TECHNOLOGY IS PROHIBITED.				THIRD ANGLE PROJECTION 			TITLE: INSTRUCTION SHEET MIL-C-24308 WELDING						
REV.	APP'D	DATE	SCALE 1:0.4	DIMENSIONS IN INCHES [mm]	DRAWN	MH	06/07/2006	NUMBER:	NS13118	REV:	C	SOLID SEALING TECHNOLOGY, INC. SHEET 1 OF 2	
C	OG	12/05/2008	NS13118-01X1		ENG APPR.	OG	06/09/2006						

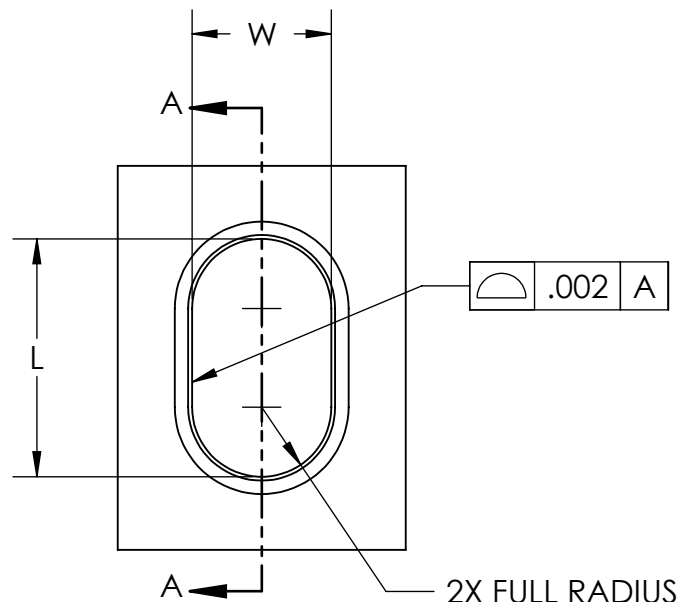

L & W ARE BASIC DIMENSIONS

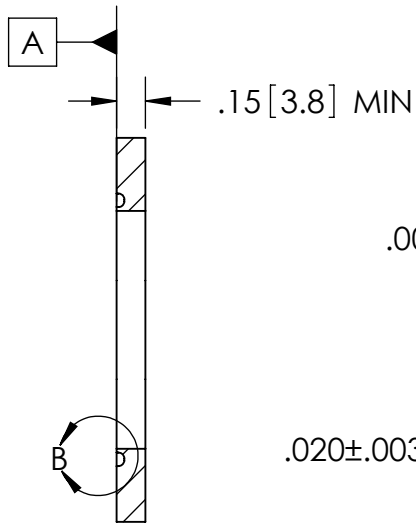

SECTION A-A

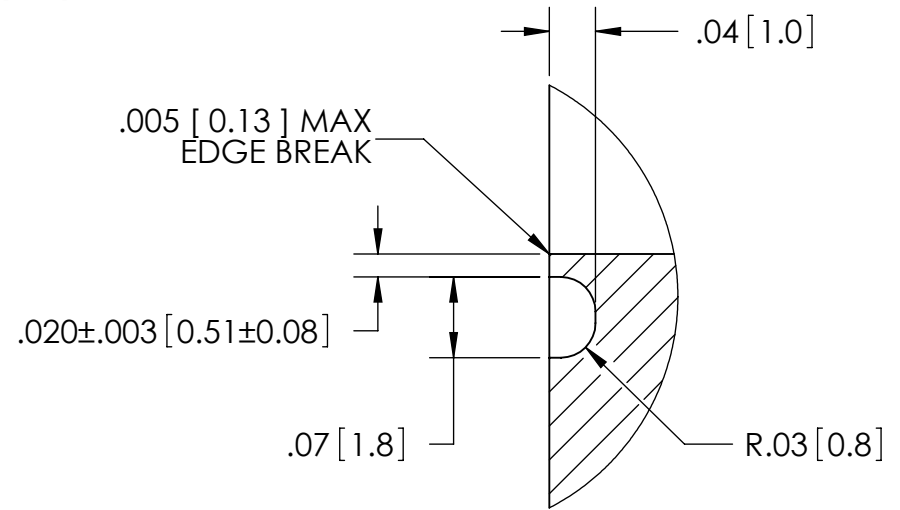

DETAIL B
SCALE 6 : 1

CONNECTOR PART NO.	CONNECTOR # OF PINS	L	W
FA13118	9	1.239 [31.47]	0.725 [18.42]
FA13119	15	1.567 [39.80]	0.725 [18.42]
FA13121	25	2.107 [53.52]	0.725 [18.42]
FA13122	50	2.743 [69.67]	0.837 [21.26]
FA16640	62	2.743 [69.67]	0.725 [18.42]

SUB-D CONNECTORS
RECOMMENDED
HOLE & WELD PREP
DIMENSIONS

- SEE SHEET 1 FOR WELDING INSTRUCTIONS -

PROPRIETARY AND CONFIDENTIAL THE INFORMATION CONTAINED IN THIS DRAWING IS THE SOLE PROPERTY OF SOLID SEALING TECHNOLOGY. ANY REPRODUCTION IN PART OR AS A WHOLE WITHOUT THE WRITTEN PERMISSION OF SOLID SEALING TECHNOLOGY IS PROHIBITED.				THIRD ANGLE PROJECTION 			TITLE: INSTRUCTION SHEET MIL-C-24308 WELDING						
REV.	APP'D	DATE	SCALE 1:1	DIMENSIONS IN INCHES [mm]	DRAWN	MH	06/07/2006	NUMBER:	NS13118	REV:	C	SOLID SEALING TECHNOLOGY, INC. SHEET 2 OF 2	
C	OG	12/05/2008	NSPRT001-01		ENG APPR.	OG	06/09/2006						